

**CITY OF  
CHANHASSEN  
INSPECTIONS DIVISION**

7700 MARKET BLVD. \* P.O. BOX 147 \* CHANHASSEN, MN 55317  
952-227-1180 \* FAX 952-227-1190

**DECKS**

**GENERAL REQUIREMENTS:**

- 1) Complete a building permit application form.
- 2) Enclose 2 copies of a site plan, or survey, showing the deck location, and distances to property lines, all buildings, pools, septic sites, wells or any other similar structures on the property.
- 3) Submit 2 copies of plans showing the proposed design. Plans shall be drawn to scale and shall include the following:
  - A. The Floor Plan:
    - Proposed deck size
    - Size, spacing & direction of floor joists
    - Size and type of decking
    - Size & location of posts & footings
    - Size of beams
    - Species of lumber to be used
    - Roof design if a future porch is a consideration
  - B. Elevation Plan:
    - Height of deck above grade
    - Diameter & depth of footings
    - Guardrail design & dimensions
    - Details of stairs
- 4) Allow a minimum of 10 working days for plan review.
- 5) Read and follow all notes and/or changes on the approved plans. If you have questions, please call for assistance
- 6) City approved plans & permit card must be available on the job site at all times.
- 7) State law requires that utilities be located prior to any construction. Call Gopher State One Call at 651-454-0002.

- 8) The electrical code requires overhead power lines to be located a minimum 10 feet above decks and platforms. Existing lines may need to be raised if a new deck is to be installed beneath them.
- 9) When locating a deck care must be given to the location of existing gas and electric meters, wells, and septic systems. These may need to be relocated to allow for construction of the deck. Septic systems and wells may be difficult to relocate, requiring an alternative location for the deck. Prior to placement of any deck that will interfere with these devices, contact the Inspections Division.

### **SETBACK RESTRICTIONS:**

- 1) Minimum required setback distances from the property lines may vary within the city. In an RSF District the setbacks from the property lines for attached decks are **generally** as follows:
  - Front & rear yards, 30 feet
  - Side yards, 10 feet
  - Corner lots, 30 feet street sides, 10 feet other sides
  - Lakeshore, 75 feet
  - Wetlands special restrictions: Consult Planning Department
- 2) Unenclosed decks may project into the required setbacks 5 feet. However, they may not encroach on to a utility or drainage easement.
- 3) If the possibility of adding a porch is a consideration, porches may not project into the required setback.
- 4) **Any setback questions should be discussed with a member of the Planning Department.** Call (952) 227-1100.

### **GENERAL BUILDING CODE REQUIREMENTS:**

- 1) Footings: Minimum 42" depth. Size based on allowable soil bearing pressure of 1500 pounds per square foot.
- 2) Decks need to be designed for a 40 pound per square foot live load and balconies to a 60 pound per square foot live load. Decks exposed to the weather must be constructed of approved wood with natural resistance to decay such as redwood, cedar or treated wood, or other material (composite plastics, etc.) with prior approval of the building inspector.
- 3) Columns and posts in contact with the ground or embedded in concrete, earth or masonry must be of special pressure treated wood approved for ground contact. Columns and posts must be restrained at top and bottom to prevent lateral movement.
- 4) Decks, balconies and open sides of landings and stairs which are more than 30" above grade or a floor below must be protected by a guard not less than 36 inches in height. Open guard at sides of stairs require intermediate rails of a pattern such that a sphere 4 inches in diameter cannot pass

through.

- 5) If a stairway is to be provided, it must be not less than 36 inches in width. Stairways may be constructed having an 7-3/4-inch maximum rise (height) and a 10-inch minimum run (length). The largest rise and run may not exceed the smallest corresponding tread rise or run by more than 3/8 inch. Stairway illumination is required by the code.
- 6) A nosing not less than 3/4 " but not more than 1 1/4 " shall be provided on stairways with solid risers. The greatest nosing projection shall not exceed the smallest projection by more than 3/8 ". Note: a nosing is not required where the tread depth is a minimum of 11".
- 7) Handrails are required on all stairways having 4 or more risers. Type I circular handrails may not be less than 1 1/4" nor more than 2 1/4 " in cross sectional area. Type II handrails must have a finger recess on both sides of the handrail and be a minimum of 1 1/4 "to a maximum of 2 3/4 "above the finger recess. Top of handrail must be not less than 34 inches nor more than 38 inches above the nosing (front edge) of treads and must be returned to a wall or post.
- 8) Floor joists spaced at 24" o.c. require 1-1/2" minimum decking. 5/4", 1" and 3/4" decking, requires 16" o. c. maximum spacing of floor joists. See chart for allowable joist spans.

FLOOR JOISTS	2x6			2x8			2x10			2x12		
	12"OC	16"OC	24"OC	12"OC	16"OC	24"OC	12"OC	16"OC	24"OC	12"OC	16"OC	24"OC
Ponderosa Pine	9-6	8-4	7-0	12-6	11-0	9-3	15-11	14-0	11-4	18-9	16-5	13-10
Southern Pine	10-9	9-9	8-6	14-2	12-10	11-0	18-0	16-0	13-1	21-9	19-10	15-5
Western Cedars	9-2	8-4	7-0	12-1	10-7	8-11	15-5	12-0	11-4	18-1	15-0	12-9
Western Woods	9-2	8-4	7-0	12-1	10-7	8-11	14-11	13-0	10-6	17-5	15-3	12-2

- 9) Joists may cantilever over beams a maximum of 24", beams may cantilever over posts a maximum of 12". If a larger cantilever is desired, a design prepared by a professional engineer, must be submitted for review and approval prior to construction.
- 10) Beams must be nailed together, set on top of posts and spliced over posts.
- 11) Joists & beams must bear their full width or be supported by approved hangers.
- 12) All fasteners must be corrosion resistant and all hangers require approved fasteners. Screws are not allowed unless approved by the hanger manufacturer.
- 13) If the deck is attached to the house, the deck rim-joist (ledger) must be attached to the house rim-joist with 3/8" lag bolts or equivalent type fastener, installed to resist withdrawal, at 16" o.c. into a solid wood rim-joist or wood blocking. If the floor frame assembly does not allow for 16" o.c. spacing, install 2 bolts to each floor joist or truss, maximum spacing of 24" o.c. These positive connections to existing structure must be verified during inspection.
- 14) All connections between the deck & house must be properly flashed. The flashing shall be installed to prevent water from entering the exterior wall envelope.
- 15) House cantilevers **must not support the deck**, unless designed for deck load support. Contact the Building Department for information if supporting the deck on a cantilevered floor assembly.

- 16) Required inspections:
  - Footing, prior to placement of concrete.
  - Framing, required before installing decking if deck is less than 48" above grade, otherwise optional.
  - Final, when complete and before occupying deck.
  
- 17) If the possibility of adding a porch is a consideration, the footings and structure should be designed accordingly. Indicate the future roof design on the plans.

**Please contact the Inspections Division at 952-227-1180 if you have any questions.**

TO BE USED AS AN EXAMPLE ONLY

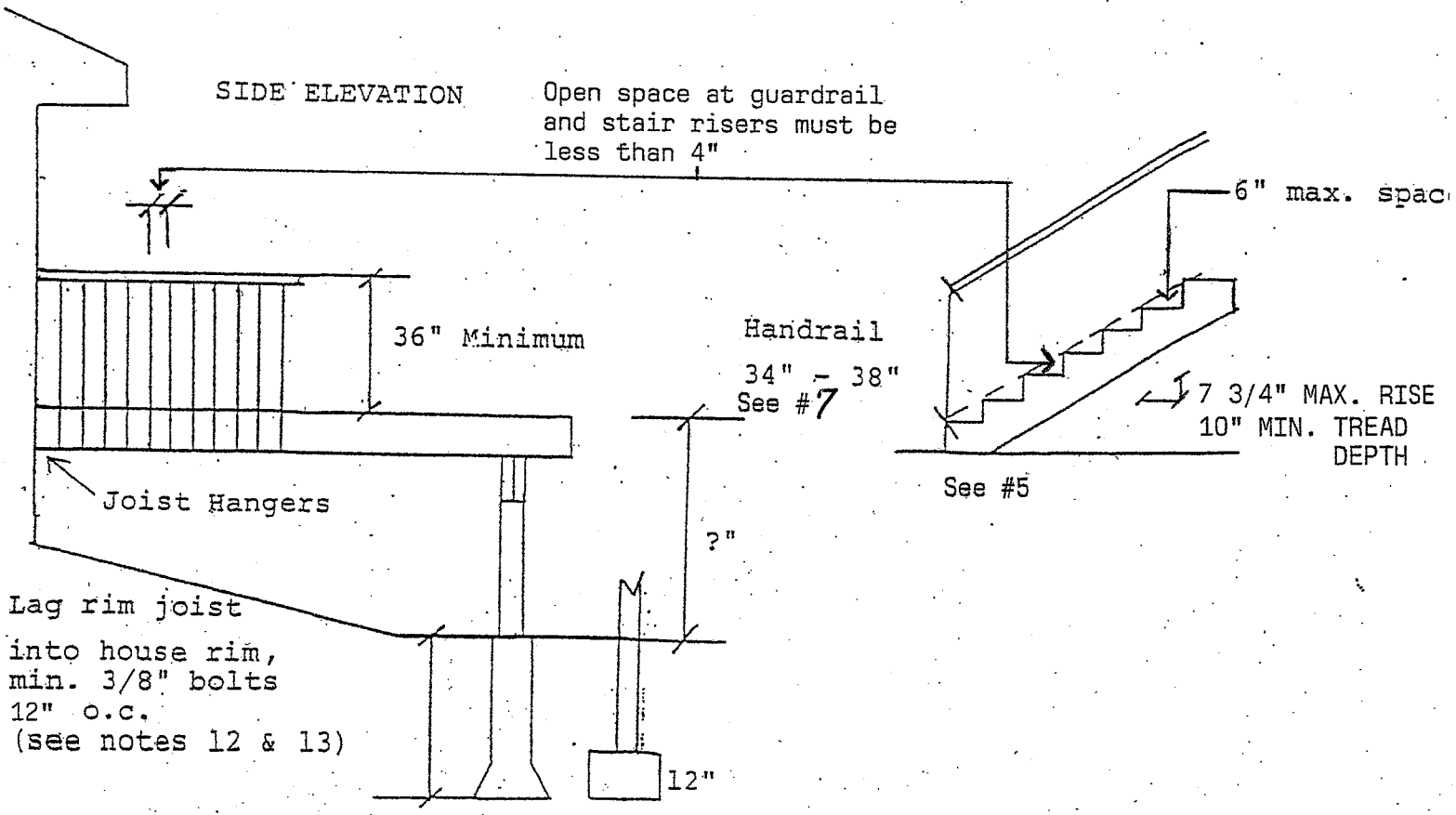
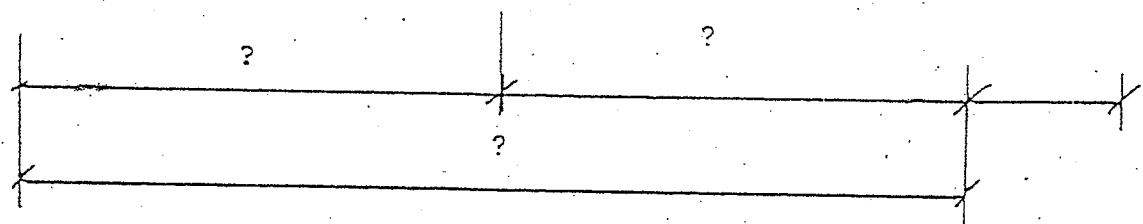
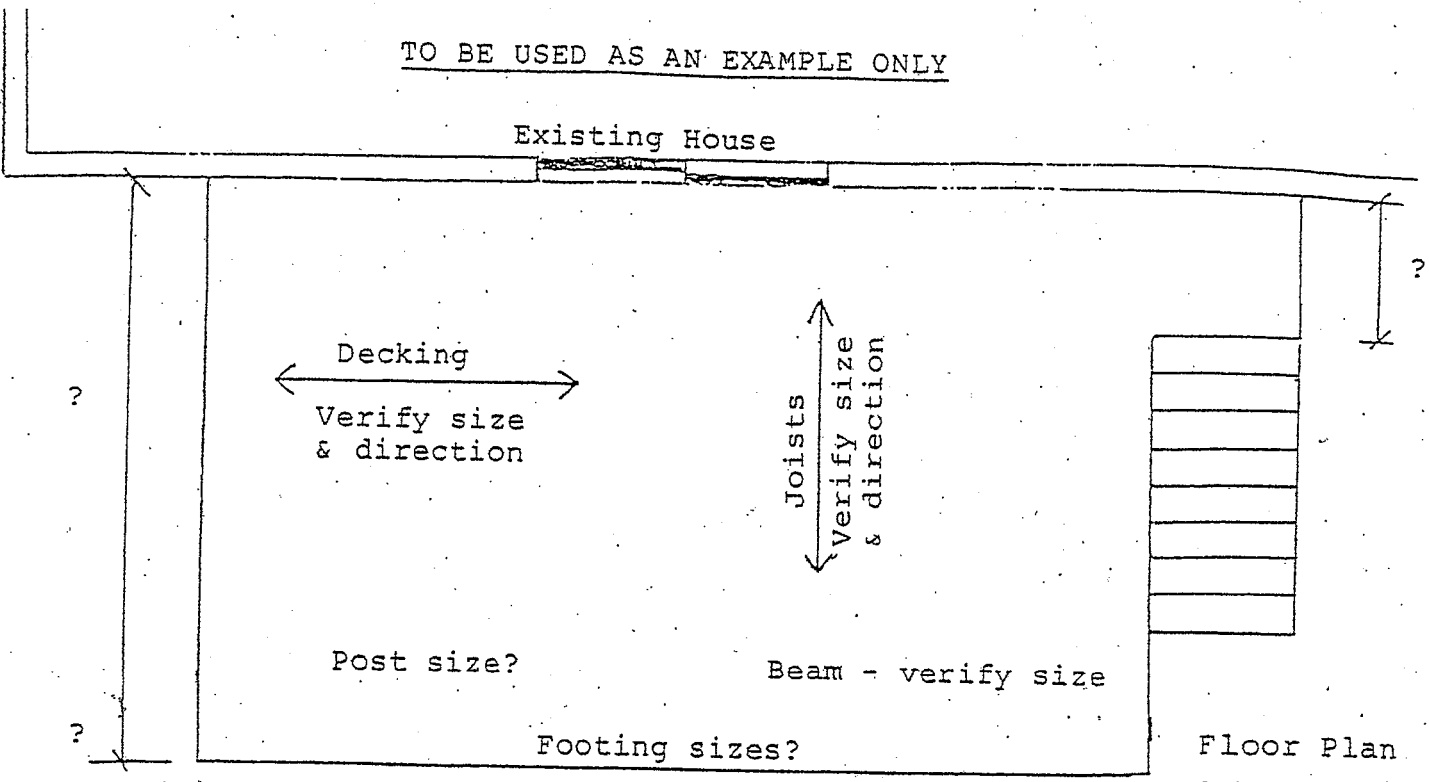

Concrete footings, size determined by load  
1500 pounds per sq. ft. bearing capacity allowed.

**R311.5.6.3 Handrail grip size.** All required handrails shall be of one of the following types or provide equivalent graspability.

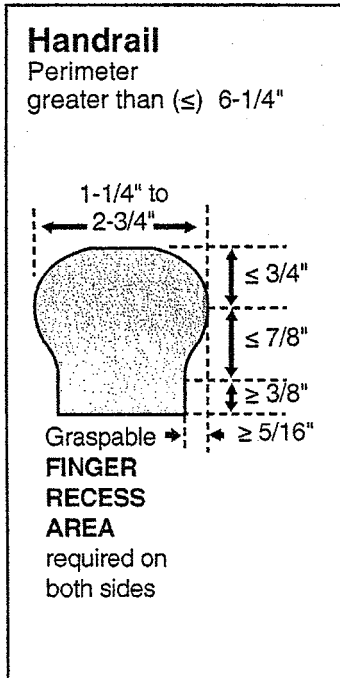

1. Type I. Handrails with a circular cross section shall have an outside diameter of at least 1 1/4 inches (32 mm) and not greater than 2 inches (51 mm). If the handrail is not circular it shall have a perimeter dimension of at least 4 inches (102 mm) and not greater than 6 1/4 inches (160 mm) with a maximum cross section of dimension of 2 1/4 inches (57 mm).

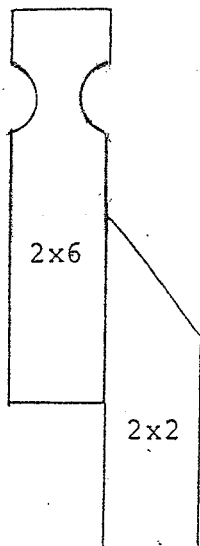
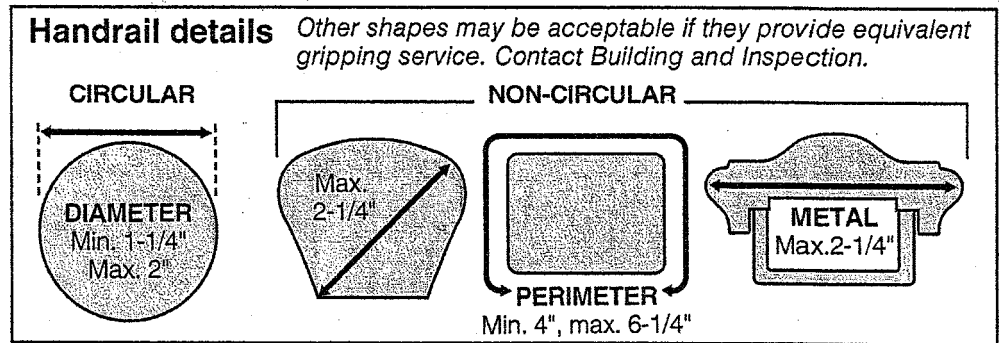

2. Type II. Handrails with a perimeter greater than 6 1/4 inches (160 mm) shall provide a graspable finger recess area on both sides of the profile. The finger recess shall begin within a distance of 3/4 inch (19 mm) measured vertically from the tallest portion of the profile and achieve a depth of at least 5/16 inch (8 mm) within 7/8 inch (22 mm) below the widest portion of the profile. This required depth shall continue for at least 3/8 inch (10 mm) to a level that is not less than 1 3/4 inches (45 mm) below the tallest portion of the profile. The minimum width of the handrail above the recess shall be 1 1/4 inches (32 mm) to a maximum of 2 3/4 inches (70 mm). Edges shall have a minimum radius of 0.01 inch (0.25 mm).

